

MANUFACTURER-SPECIFIC RETURN CRITERIA



BPW Hub Unit

Criteria:

Identification

Completeness

Mechanical damage

Corrosion

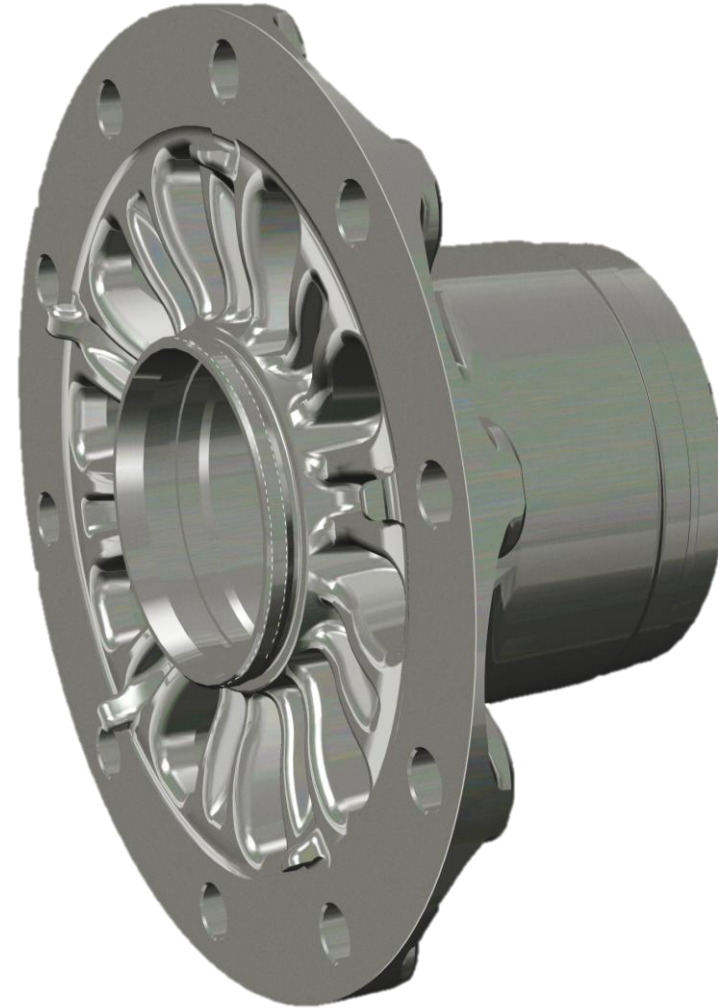

MANUFACTURER-SPECIFIC RETURN CRITERIA



BPW Hub Unit

Criteria:

Identification

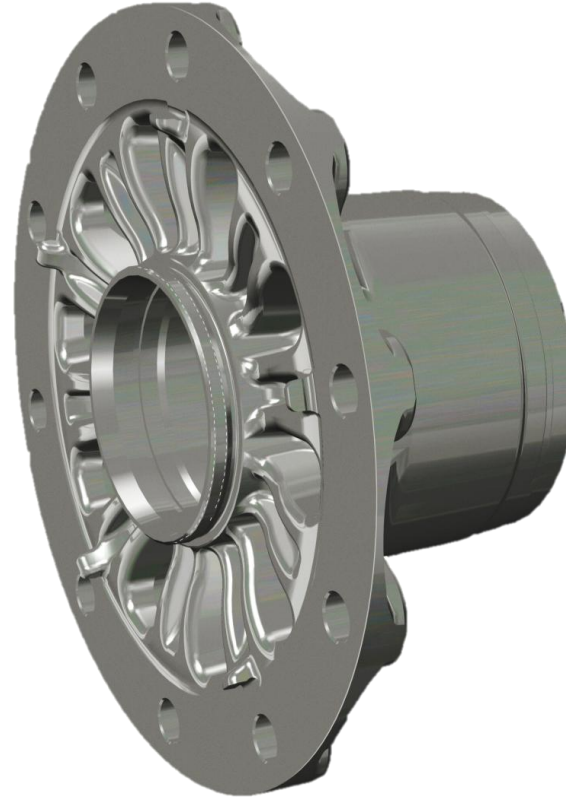

Acceptable



Acceptable

MANUFACTURER-SPECIFIC RETURN CRITERIA



BPW Hub Unit

Criteria:

Completeness

Components without existing capsule are not accepted.



Not acceptable



Acceptable

MANUFACTURER-SPECIFIC RETURN CRITERIA



BPW Hub Unit

Criteria:

Completeness

Components without existing bearing are not accepted.



Acceptable

MANUFACTURER-SPECIFIC RETURN CRITERIA



BPW Hub Unit

Criteria:

Completeness

Wheel studs and brake discs must be dismantled.

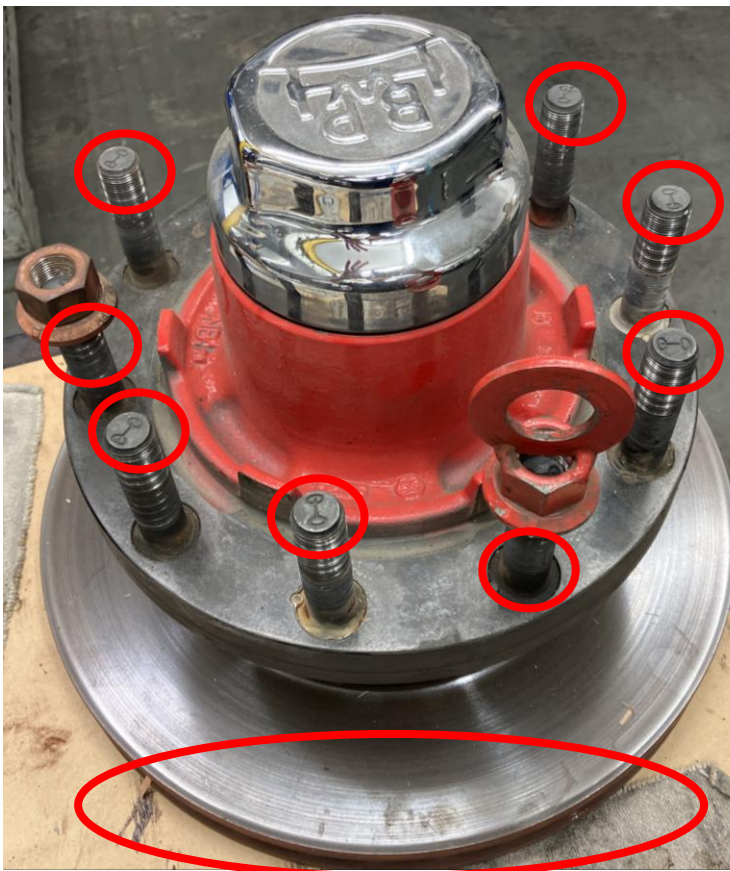

Not acceptable



Acceptable

MANUFACTURER-SPECIFIC RETURN CRITERIA



BPW Hub Unit

Criteria:

Mechanical damage

Quirks in the bores are not acceptable. Indentations on the flange are not acceptable.



Not acceptable



Not acceptable

MANUFACTURER-SPECIFIC RETURN CRITERIA



BPW Hub Unit

Criteria:

Mechanical damage

Quirks and breaks in the wheel centering are not acceptable.

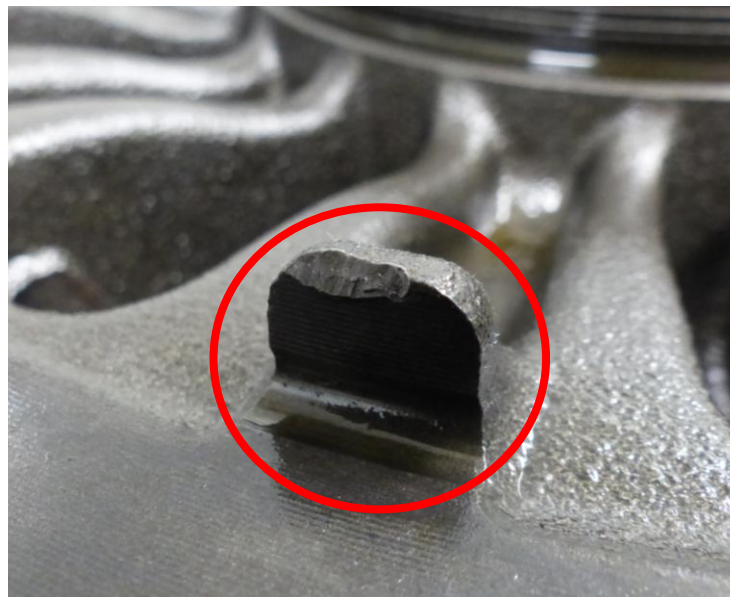

Not acceptable

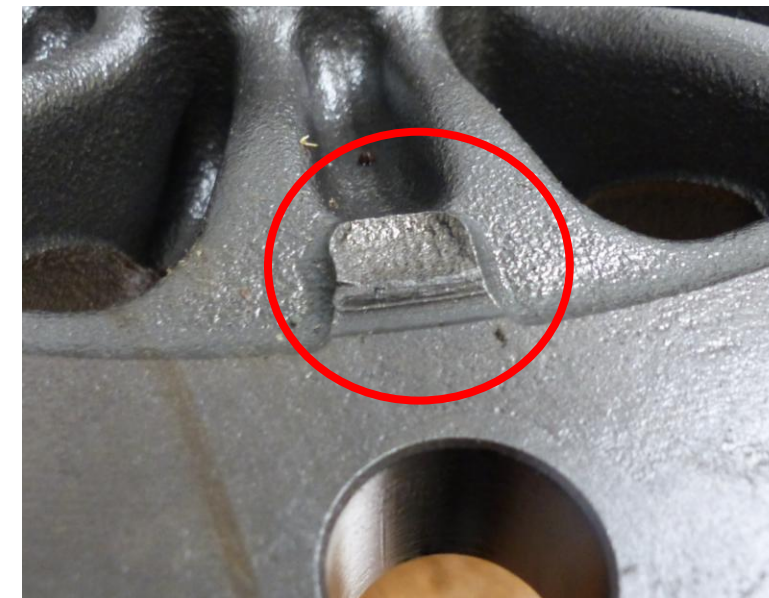

Not acceptable

MANUFACTURER-SPECIFIC RETURN CRITERIA



BPW Hub Unit

Criteria:

Mechanical damage

General flaws/shocks are not acceptable.



Not acceptable

MANUFACTURER-SPECIFIC RETURN CRITERIA



BPW Hub Unit

Criteria:

Mechanical damage

Impact points are not acceptable.



Not acceptable



Not acceptable

MANUFACTURER-SPECIFIC RETURN CRITERIA



BPW Hub Unit

Criteria:

Corrosion

Corrosion front and back are acceptable.



Acceptable



Acceptable

„Components without existing bearing are not accepted“ – see slide 1.

MANUFACTURER-SPECIFIC RETURN CRITERIA



BPW Hub Unit

Criteria:

Corrosion

Insides free of corrosion.
Brownish fat acceptable, Rust
film at locking ring acceptable.



Acceptable



Acceptable

MANUFACTURER-SPECIFIC RETURN CRITERIA



BPW Hub Unit

Additional information:

Only genuine BPW Hub Units are acceptable.

Non-BPW Hub Units or Hub Units remanufactured/repaired by third-parties are not acceptable.