

## Common Rail Injector (CRI/CRIN)

### Criteria:

Identification

Completeness

Mechanical damage

Corrosion

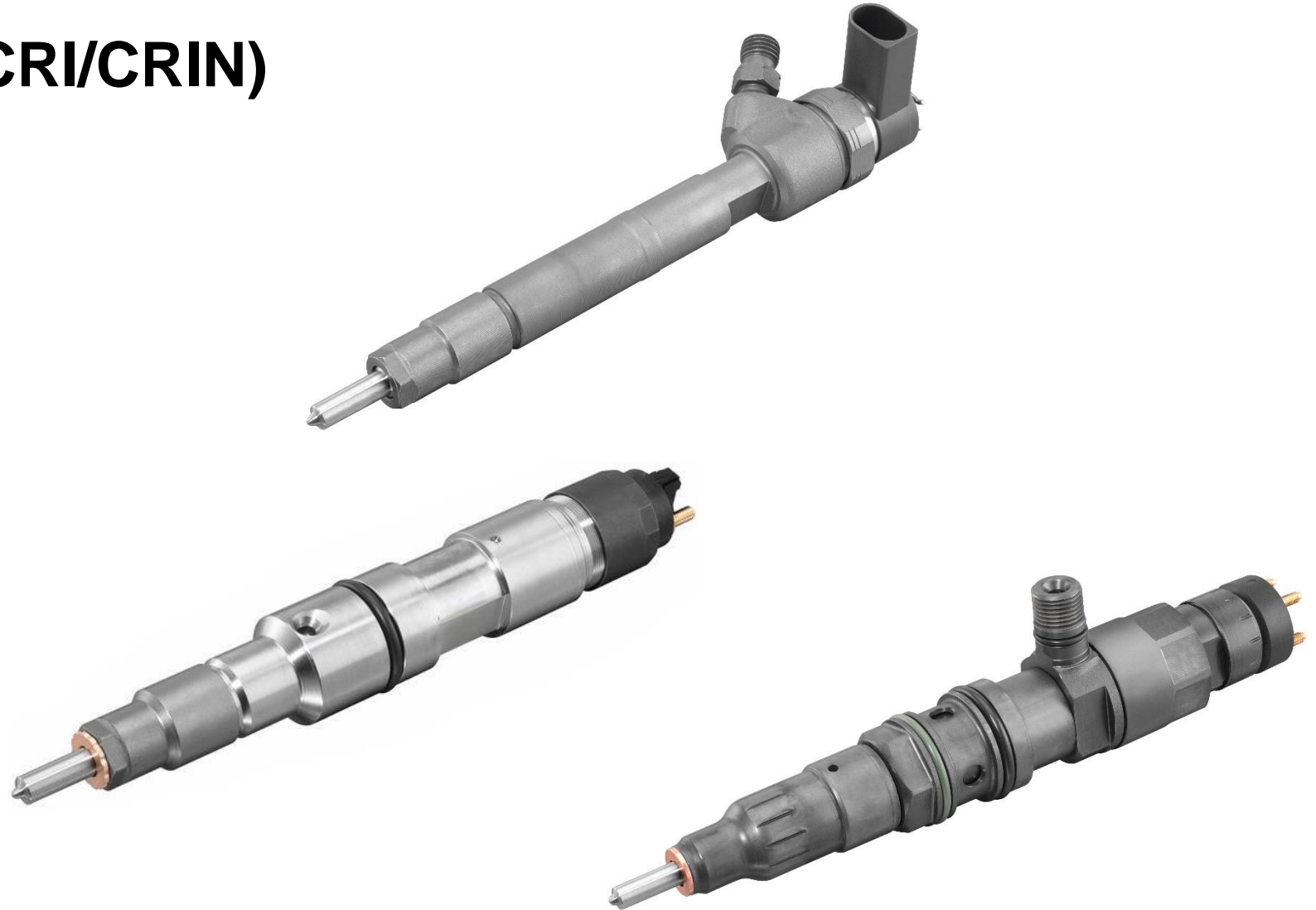

## Common Rail Injector (CRI/CRIN)

### Criteria:

#### Identification

Part number must be legible



CRI

Acceptable



CRIN

Acceptable

## Common Rail Injector (CRI/CRIN)

### Criteria:

#### Completeness

Aggregate dismantled, nozzle missing, inject connector missing or magnet unit missing is not acceptable



Not acceptable



Not acceptable

## Common Rail Injector (CRI/CRIN)

### Criteria:

Mechanical damage

Damage on connector or magnet unit is acceptable



Acceptable



Acceptable

## Common Rail Injector (CRI/CRIN)

### Criteria:

#### Mechanical damage

Damage on body caused by inappropriate handling (e.g. hammer) are not acceptable



Not acceptable

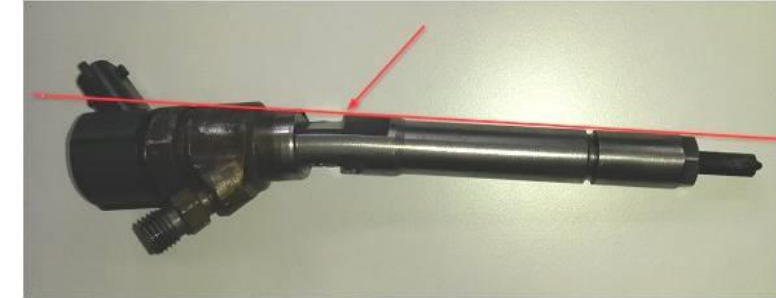

Not acceptable

## Common Rail Injector (CRI/CRIN)

### Criteria:

Mechanical damage

Small damages on housing are acceptable



Acceptable



Acceptable

# Common Rail Injector (CRI/CRIN)

## Criteria:

### Corrosion

No corrosion or separated corrosion spots is acceptable;  
Heavy large area corrosion is not acceptable;



Acceptable



Acceptable